



Ref. 10002 SP

CALIBRO DIGITALE

ELECTRONIC DIGITAL CALIPER - PIED A COULISSE DIGITAL

I CARATTERISTICHE TECNICHE

Capacità:	0-150mm / 0-200mm / 0-300mm
Risoluzione:	0.01 mm
Precisione:	0.03 mm
Ripetibilità:	0.01 mm
Velocità massima per spostamento corsoio:	1.5 m/s
Display:	con indicazione \pm
Alimentazione:	Pile alcaline 1,5V
Temperatura di lavoro:	0-40°C
Temperatura di stoccaggio:	-20 / 60°C

F SPECIFICATIONS

Measuring range:	0-150mm / 0-200mm / 0-300mm
Resolution:	0.01 mm
Accuracy:	0.03 mm
Repeatability:	0.01 mm
Maximum measuring speed:	1.5 m/s
Display:	\pm indication
Power:	One battery 1,5V
Operating temperature:	0 to 40°C
Storage temperature:	-20 to 60°C

GB CARACTERISTIQUES TECHNIQUES

Capacité:	0-150mm / 0-200mm / 0-300mm
Résolution:	0.01 mm
Précision:	0.03 mm
Répétibilité:	0.01 mm
Vitesse maxi de déplacement du coulisseau:	1.5 m/s
Display:	avec indication \pm
Alimentation:	Pile alcaline 1,5V
Température de travail:	0-40°C
Température de stockage:	-20 - 60°C

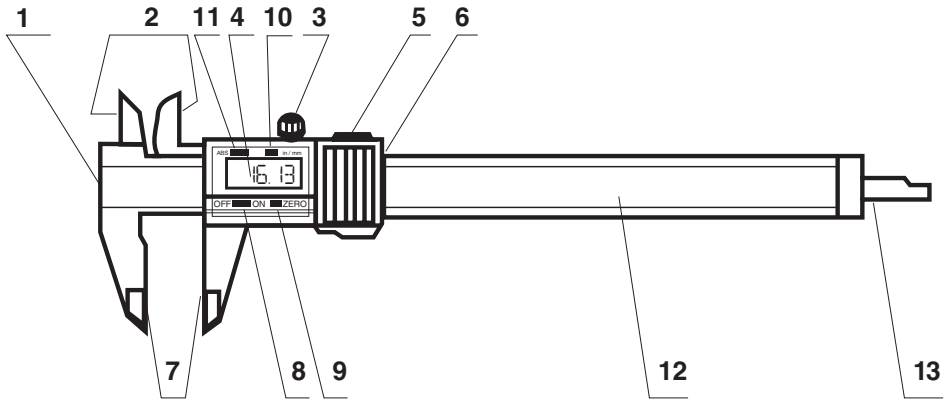

- | | |
|--|--|
| <p>1. Asta calibro
BeamCorp</p> <p>2. Becchi per misure interne
Internal measuring face
Becs pour mesures intérieures</p> <p>3. Vite di bloccaggio
Position locking screw
Vis de blocage</p> <p>4. Display
Display
LCDdisplay</p> <p>5. Uscita stampante
Data output
Sortie pour imprimieur</p> <p>6. Alloggiamento pile
Battery cap
Logement pile</p> <p>7. Becchi per misure esterne
External measuring face
Becs pour mesures extérieures</p> <p>8. Tasto accensione/spegnimento
ON/OFF BUTTON</p> <p>9. Tasto d'azzeramento
Zero setting
Bouton de mise à zero</p> | <p>10. Selezione unità di misura mm/inch
mm/inch conversion
Sélecteur unité de mesure</p> <p>11. Premere il tasto ABS per impostare la misura a partire da un punto diverso dallo zero (misura relativa).
Premendo nuovamente ABS dopo aver spostato il corsoio si legge la misura riferita allo zero assoluto (misura assoluta).
Press ABS to get the measurement from an intermediate point (relative mesure).
After moving the slider, press ABS again to get the measurement from the absolute zero (absolute measurement).
Pousser ABS pour obtenir la mesure à partir de n'importe quel point (mesure relative).
Après avoir bougé le couloir pousser ABS à nouveau pour obtenir la mesure à partir du zero absolu (mesure absolute).</p> <p>12. Asta graduata
Scale face Surface graduée</p> <p>13. Astina di profondità
Depth measuring blade
Tige de profondeur</p> |
|--|--|

